



# INSTALLATION MANUAL FOR PHOTOVOLTAIC MODULES

1. PURPOSE OF INSTALLATION MANUAL	2
2. SAFETY PRECAUTIONS	2
2.1. GENERAL WARNING	2
2.2. INSTALLATION SAFETY	2-3
2.3. FIRE SAFETY	3
3. LIMITATION OF LIABILITY	4
4. GENERAL INFORMATION	4-5
5. LABEL	5
5.1. VOLTA AND VOLTA+ SERIES LABELING	5
5.2. GALVANI SERIES LABELING	6
6. MECHANICAL INSTALLATION	6
6.1. SITE SELECTION	6
6.2. TILT ANGLE	6
6.3. MOUNTING	7
6.3.1. MOUNTING USING FRAME BOLTS HOLES	7
6.3.2. MOUNTING WITH CLAMPS	7
6.3.2.1. CLAMP MOUNTING ON LONG SIDES OF THE FRAMES	8
7. WIRING	8-9
8. GROUNDING	9
9. MAINTENANCE AND REPAIR	9

#### HEADQUARTERS

Aydın Mahallesi Aydın Küme Evleri  
No: 78 06980 K.Kazan / ANKARA

#### FACTORY

Büyükoşb Mah. Nevzat Ayaz Bulvarı  
No: 2 Korgun OSB, Korgun / ÇANKIRI



/setsolartr

[www.setsolar.com.tr](http://www.setsolar.com.tr)



## 1. PURPOSE OF INSTALLATION MANUAL

Thank you for choosing SET SOLAR PV modules. This manual describes the correct installation of photovoltaic panels. We recommend that you read this manual before installation and follow the safety precautions during installation.

## 2. SAFETY PRECAUTIONS

Professional installer must read these guidelines carefully and strictly follow these instructions. Failure to follow these instructions may result in death, injury or property damage. The installation and handling of PV modules require professional skills and should only be performed by qualified professionals. Please retain this manual for future reference.

### 2.1. GENERAL WARNING

- All modules must be installed by licensed electricians.
- Electricians must take precautions about occupational health and safety.
- All Set Solar PV module have junction box, wires and connectors so PV module do not need any extra wires.
- Do not use any mirror or glass etc. for focusing sunlight to the PV module
- PV module are used for converting sunlight to DC electrical energy so they must be set up outside.
- Do not paint the panel surface or backsheet.
- Do not paste or attach anything to the panel's backsheet.
- Do not remove anything from the PV module. PV module must be disassembled by professionals.

### 2.2. INSTALLATION SAFETY

- Insulated gloves must be worn when carrying the PV module.
- Insulated tools should be used for electrical connections.
- Inappropriate transportation or installation can cause the panel to become damaged.
- Please do not lift PV module from junction box or wires.
- Please do not put excessive pressure on PV panels.
- Do not put any foreign object on the PV module.
- Do not drop PV module or do not throw anything towards PV panel.
- Backsheet of the PV module should avoid direct contact the sun.
- Do not wear any metal accessories during operation.
- Do not assembly the PV module under the rainy or windy conditions.
- Safety procedures must be followed for all parts of the PV module installation process.
- Do not install the PV module near open flame or flammable materials.

- Insulated gloves must be worn when installing the PV modules.
- Please do not drill into the frame.
- Under normal conditions, a photovoltaic module is likely to experience conditions that produce more current and/or voltage than reported at standard test conditions (STC). Accordingly, the values of  $I_{sc}$  and  $V_{oc}$  marked on this module should be multiplied by a factor of 1.25 when determining component voltage ratings, conductor capacities fuse sizes, and size of controls connected to the PV output.
- Matte color plates can be used during installation for avoiding any current increase.
- PV module must be grounded properly. Recommended connectors and grounding wire must be used. Grounding wire must be fixed to the PV module properly.



### 2.3. FIRE SAFETY

- Related regulations must be followed for stable structural integrity.
- Do not setup PV module on the unsuitable roofs.
- Do not assembly the PV module next to the flammable material and flammable facilities.
- Please refer to local laws and regulations before installing modules and abide by requirements on building fire protection. According to the corresponding certification standards, the fire rating of Set Solar modules is Class C.



### 3. LIMITATION OF LIABILITY

Set Solar is not responsible for any kind of damage, including but not limited to module operation and system installation error, and personnel injury, hurt, and property loss caused by failure to following the instructions in this Manual.

### 4. GENERAL INFORMATION

Module Type	Volta SETM60	Volta+ SETM72	Volta+ SETM120	Volta+ SETM144	Galvani SETT144	Galvani SET72
Class of protection against electrical Shock	Sinif II					
Maximum system Voltage (Vsys)	1500					
Voltage at open-circuit (Voc)	40.93	49.29	41.12	49.47	51.86	52.14
Current at short-circuit (Isc) (A)	10.26	10.19	11.59	11.60	13.9	14.15
PV module maximum power (Pmax)(W)	335	400	375	455	590	605
Maximum overcurrent production rating (A)	15	15	20	20	30	30
Power, current and voltage tolerance	±3%					
Temperature coefficient for voltage at open-circuit Beta [%/°C]	-0.282	-0.254	-0.25	-0.25	-0.25	-0.25
Temperature coefficient for maximum power Gama [%/°C]	-0.376	-0.318	-0.30	-0.30	-0.30	-0.30
Temperature coefficient for short-circuit current Alpha [%/°C]	0.043	0.054	0.045	0.045	0.045	0.045

- Set Solar PV modules operate at temperatures between -40°C and +85°C .
  - Module electrical ratings are measured under Standard Test Conditions (STC) of 1000 W/m<sup>2</sup> irradiance, with an AM1.5 spectrum, and a cell temperature of 25°C.
  - The module might produce more or less voltage or current than rated value in uncertainty condition.
  - Each module of the Volta and Volta+ series has its own cable (cross-sectional area 4 mm<sup>2</sup>) and MC4-Evo2 connectors.
  - Each module of the Galvani series has its own cable (cross-sectional area 4 mm<sup>2</sup>) and MC4- EVO 2/ QC4.10 Plus connectors. In addition, each module has three Schottky bypass diodes.
  - Type for Volta series: GP3045; maximum peak reverse voltage: 45V, forward current: 15A
  - Type for Volta+ series: TM3045-20; maximum peak reverse voltage: 45V, forward current: 20A
  - Type for Galvani series: QCM5045B; maximum peak reverse voltage: 45V, forward current: 50A and maximum function temperature ranges: -55°C / 200°C. When selecting the appropriate conductor material, this information should be taken into account and must comply with TS EN 61730-1.
- |   |   |
|---|---|
| <ul style="list-style-type: none"> <li><b>Mechanical Load;</b></li> <li>Snow Test Load: 5400 Pa</li> <li>Wind Test Load: 2400 Pa</li> </ul> | <ul style="list-style-type: none"> <li><b>Design Load;</b></li> <li>Snow: 3600 Pa</li> <li>Wind: 1600 Pa</li> <li>Safety Factor: 1.5</li> </ul> |
|---|---|

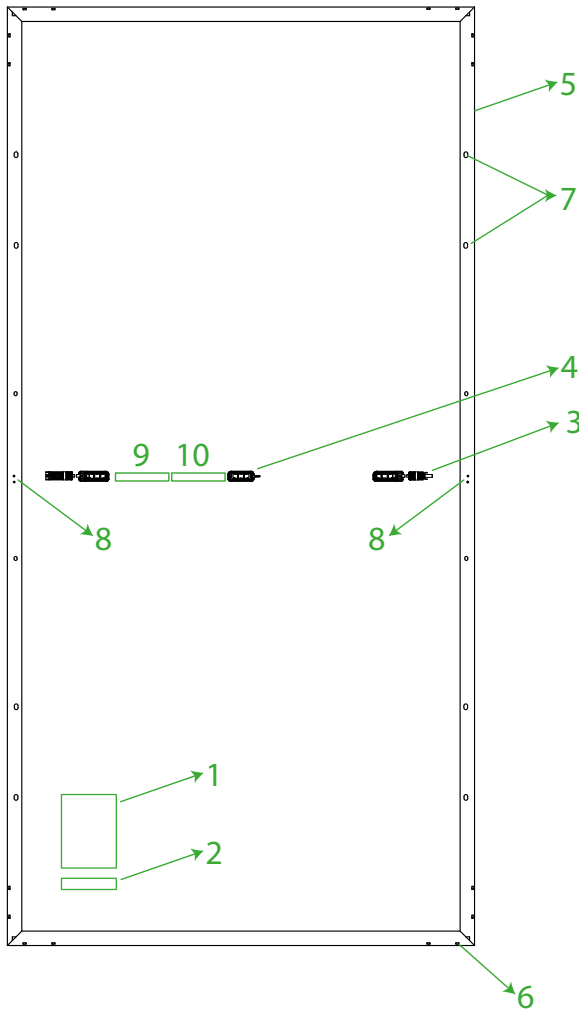

- 1. Label (9th)
- 2. Barcode (10th)
- 3. MC-4 Connector
- 4. Schottky Bypass Diode
- 5. Aluminum Frame
- 6. Drainage Holes
- 7. Mounting Holes
- 8. Grounding Hole

**Note:** For panels produced with transparent backsheet, items 1 and 2 are updated as items 9 and 10.

## 5. LABEL

All Set Solar PV modules have two barcodes and one label.

**Nameplate:** It is found on the back of the PV module. Specific information from datasheets exist in there .

**Barcode plates:** There are two barcode plates on the module. First one is found inside the top right corner of the glass. Second one is found on the frame. They contain product barcode.

### 5.1. VOLTA AND VOLTA+ SERIES LABELING



VOLTA SERIES BARCODE



VOLTA+ SERIES BARCODE

VOLTA ve VOLTA + SERIES LABEL

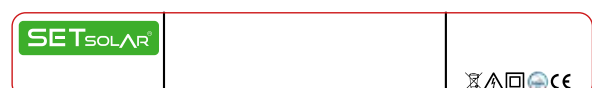

## 5.2. GALVANI SERIES LABELING



GALVANI SETT144 SERIES BARCODE



GALVANI SET72 SERIES BARCODE

### GALVANI SERIES LABEL



## 6. MECHANICAL INSTALLATION

Starting from this line, all the given instructions are recommendations. All design, installation and calculations must be done by licensed people.

### 6.1. SITE SELECTION

In most applications, Set Solar PV modules should be installed in a location where they will receive maximum sunlight throughout the year. Even minor partial shading reduces yields. A module can be considered to be unshaded if its entire surface is free from shading all year round. Sunlight should be able to reach the module even on the shortest day of the year. Constant shading conditions can affect module service lifetime, due to accelerated ageing of the encapsulation material and thermal stress on the bypass diodes.

The module's limit working ambient temperature range is from  $-40^{\circ}\text{C}$  to  $85^{\circ}\text{C}$ . Maximum altitude less than or equal to 2000m. The maximum mechanical load is 5400 Pa on the front and 2400 Pa on the back.

### 6.2. TILT ANGLE

The tilt angle measurement of the PV module refers to measuring the angle between the module and the horizontal ground surface. For different projects there are different mounting angles. Set Solar recommends that the mounting tilt angle should not be less than  $10^{\circ}$ , or in accordance with local regulations or follow the recommendations of experienced PV module installers.

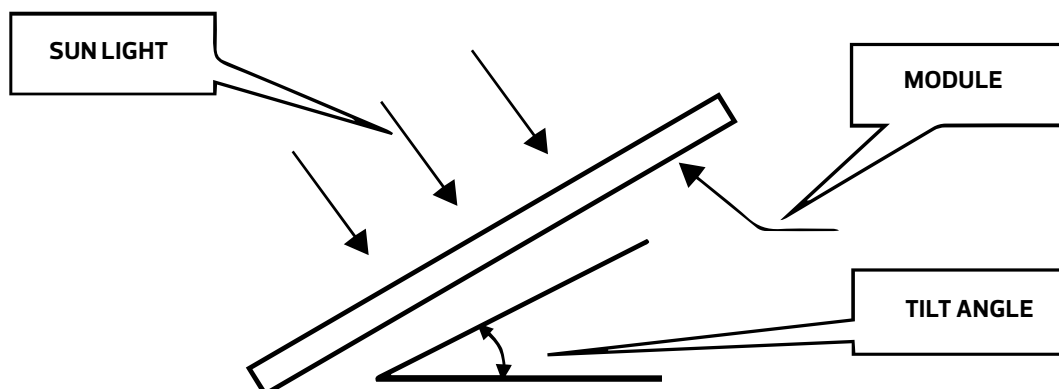

## 6.3. MOUNTING

### 6.3.1. MOUNTING USING FRAME BOLTS HOLES

Each module must be securely fastened using a minimum of 4 mounting holes (9mm×14mm) at locations shown below. For maximum security against strong winds and heavy snow falls, all 10 mounting holes should be used to secure the module.

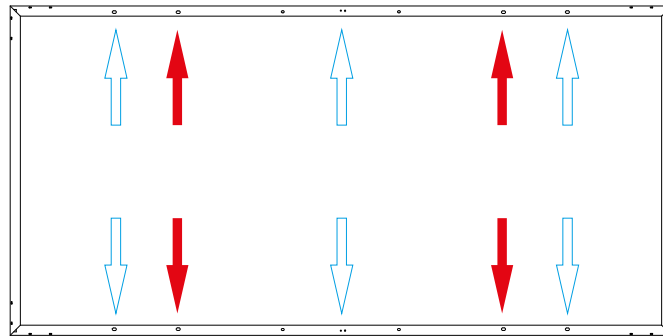

**Red Arrows:** Holes for mounting the PV modules to the substructure

**Blue Arrows:** Additional holes for maximum security

Additional units included in the diagram are as follows:

1. Stainless steel m6 nut
2. Stainless steel washer
3. Stainless steel M6 t-head bolt

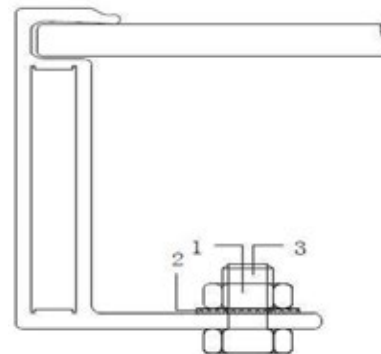

### 6.3.2. MOUNTING WITH CLAMPS

The module clamps should not come into contact with the front glass and must not deform the frame. Be sure to avoid shadowing effects from the module clamps. The module frame is not to be modified under any circumstances. When choosing this type of clamp–mounting method, please be sure to use at least four clamps on each module. Depending on the local wind and snow loads, additional clamps or support would be required to ensure the module can bear the load. The applied torque value should be big enough to fix the modules steadily. Please find detailed mounting information in the below illustration, the mounting place distance is suggested bigger than J and less than K. The min length of clamp is 50mm. The position of the clamp should be between 1/5 and 1/4 of the long side of the module.

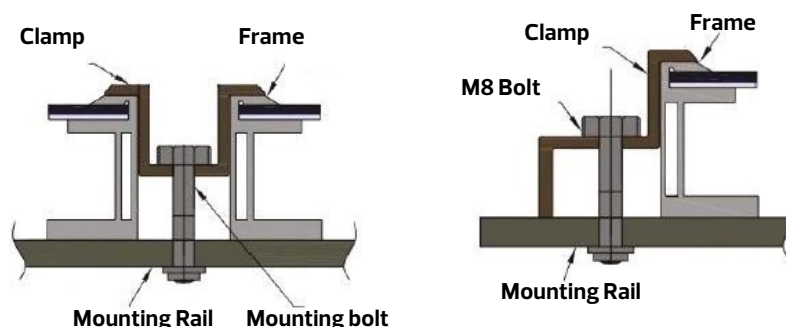

### 6.3.2.1. CLAMP MOUNTING ON LONG SIDES OF THE FRAMES

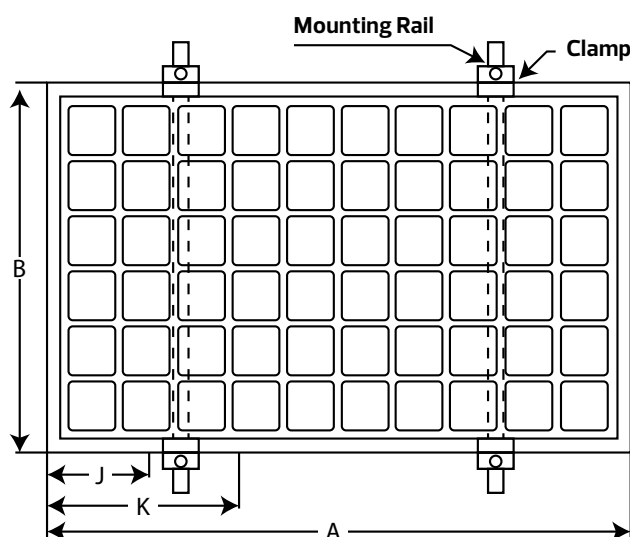

Module Type	Module Dimensions (AxB)	J (mm)	K (mm)
VOLTA SERIES SETM60	1665x1002	330	420
VOLTA SERIES SETM72	1979x1002	400	495
VOLTA+ SERIES SETM120	1755x1038	350	440
VOLTA+ SERIES SETM144	2094x1038	420	520
GALVANI SERIES SETT144	2278x1134	456	570
GALVANI SERIES SET72	2297x1134	460	575

## 7. WIRING

Modules are supplied with cables and connectors to be used for system electrical connections. It is not recommended to use modules with different configurations and electrical characteristics in the same system. To ensure proper system operation the correct cable connection polarity should be observed when connecting the modules to each other or to a load, such as inverter, a battery etc. If modules were not connected correctly, the bypass diode could be destroyed.

Modules can be connected in series to obtain a high operating voltage. The system voltage is equal to the sum of the voltage of each module. Modules can also be connected in parallel to obtain a high operating current. The system current is equal to the sum of the current of each string of modules.

Each module has two standards 90°C sunlight resistant output cables each terminated with plug & play connectors.

For field connections, use at least 4mm<sup>2</sup> copper wires insulated for a minimum of 90°C and sunlight resistance with insulation designated as PV Wire.

Under normal conditions, a module is likely to experience conditions that produce more current and/or voltage than reported at standard test conditions. The suggested fuse must be used for overcurrent protection.

Accordingly, the values of  $I_{sc}$  and  $V_{oc}$  marked on this module should be multiplied by a factor of 1.25 when determining component voltage ratings, conductor ampacities, fuse sizes, and size of controls connected to the PV output.

The maximum number of series connected modules depends on system design, the type of inverter used and environmental conditions. It should be noted that modules must not be connected together to create a voltage higher than the permitted system voltage. There is no limitation on the number of modules that can be connected in parallel; the number of modules is determined by system design parameters such as current or power output.

## 8. GROUNDING

- All module frames and mounting racks must be properly grounded in accordance with appropriate respective National Electrical Code.
- Proper grounding is achieved by bonding the module frame(s) and all metallic structural members together continuously using a suitable grounding conductor. The grounding conductor or strap may be copper, copper alloy, or any other material acceptable for use as an electrical conductor per respective National Electrical Codes. The grounding conductor must then make a connection to earth using a suitable earth ground electrode.

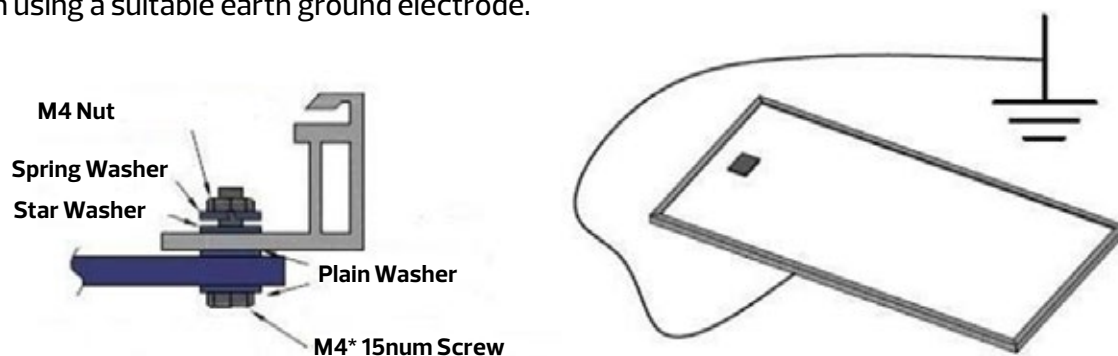

## 9. MAINTENANCE AND REPAIR

- A buildup of dust or dirt on the module(s) front face will result in a decreased energy output. Clean the panel(s) preferably once per year if possible (depend on site conditions) using a soft cloth dry or damp, as necessary. Water with high mineral content may leave deposits on the glass surface and is not recommended.
- In order to reduce the potential for electrical and thermal shock injuries, recommending that cleaning PV modules during early morning or late afternoon hours when solar radiation is low and the modules are cooler, especially in regions with hotter temperatures
- Never attempt to clean a PV module with broken glass or other signs of exposed wiring, as this presents a shock hazard.
- Never use chemicals when cleaning modules as this may affect the module warranty and energy output.
- To protect against electric shock or injury, electrical or mechanical inspections and maintenance should be performed by qualified personnel only.